

K2 PRESSION OR WALL SYSTEM

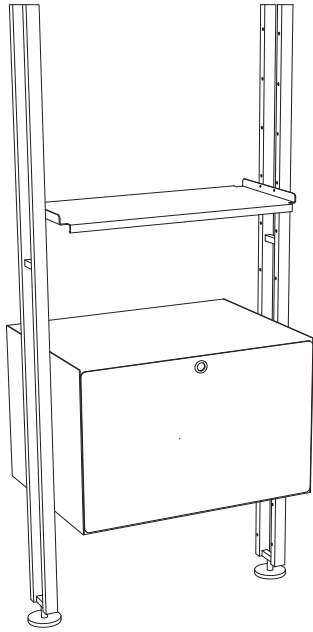





The essentiality of the K2 system allows to create furnishing solutions that fit with any area of the house: from the living area to the bedroom, the office or for exhibition spaces such as ad stores and showrooms.

FUNZIONAMENTO

Pression or wall system composed of uprights, shelves and cabinets. The holes on the uprights allow to place the components and to create a solution that fits with your needs.



FINISHES

-  Anodised aluminium
-  Matte white RAL 9010
-  Matte black RAL 9005
-  Oak wood
-  Walnut wood
-  Matte white lacquered RAL 9010

On request, components can be custom-made or coated with a special RAL colour.



FLOOR-CEILING EXTENSIBLE UPRIGHTS

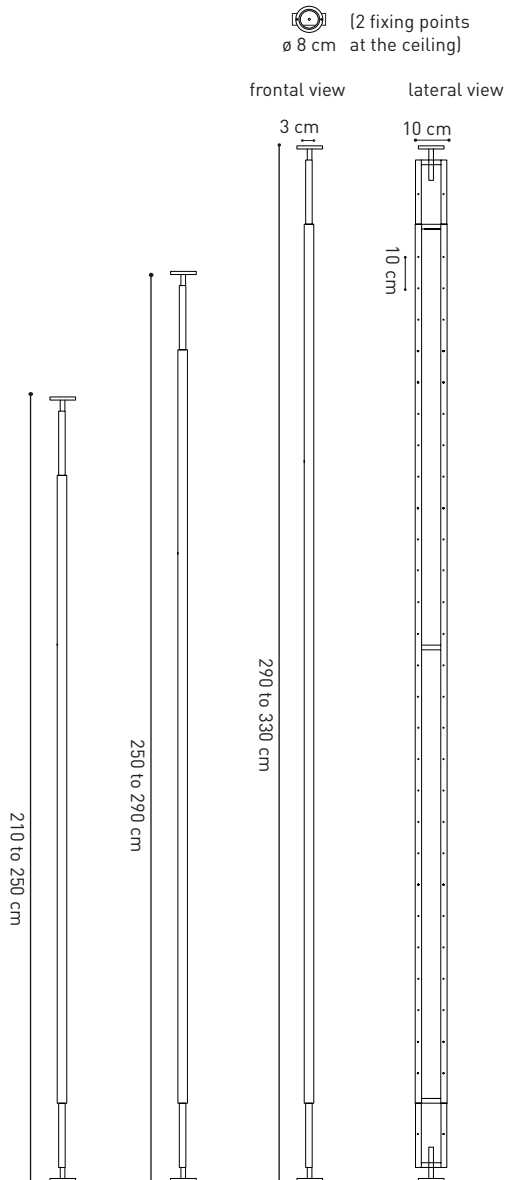

CUSTOM-MADE FLOOR-CEILING UPRIGHTS

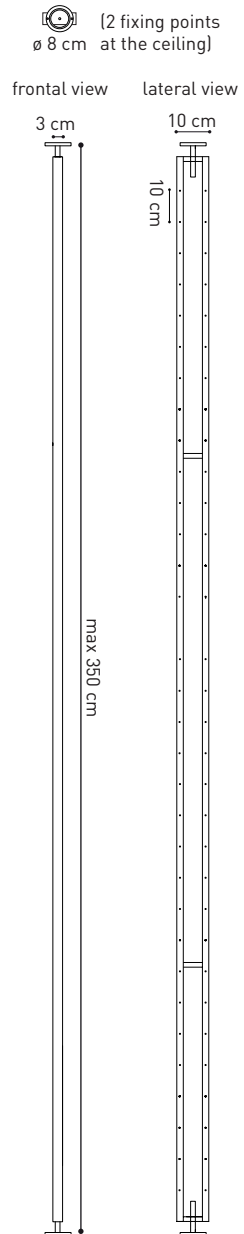

FRONTAL WALL HOOK

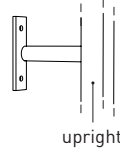

The wall hook is used in presence of a dropped ceiling, to stiffen the structure.

LATERAL WALL HOOK

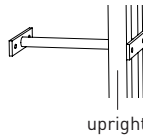

L'aggancio a parete viene utilizzato per irrigidire una struttura divisoria.

PRESSER FOOT

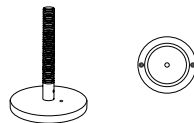

2 fixing points at the ceiling, no fixing point at the floor.



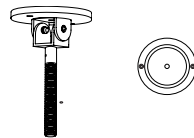





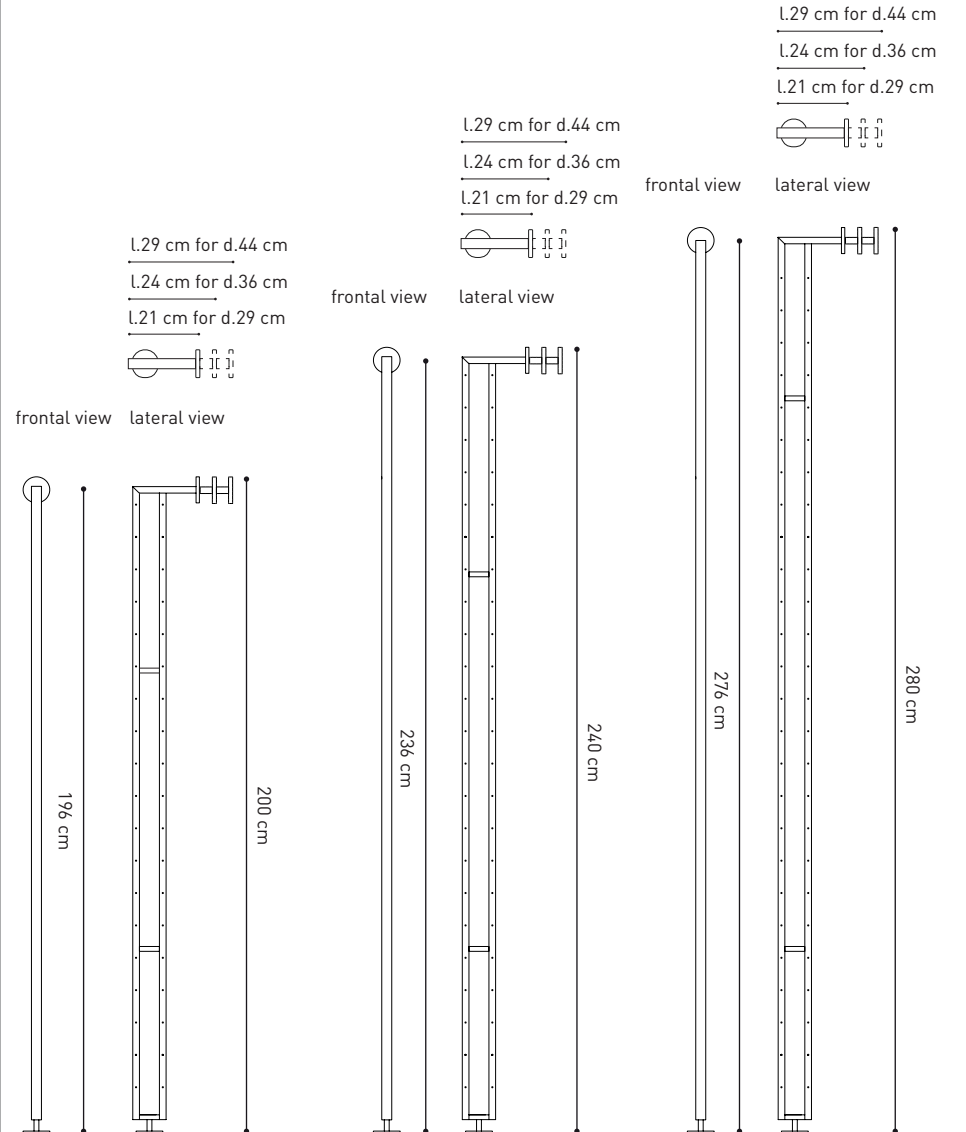

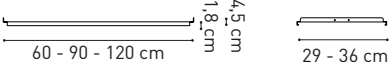
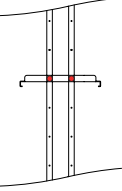

PRESSER FOOT WITH JOINT

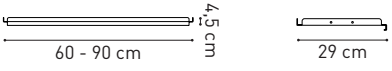
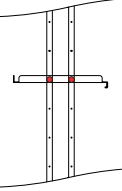

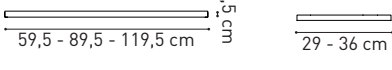
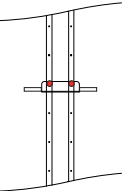



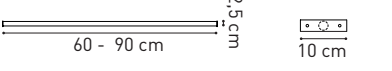
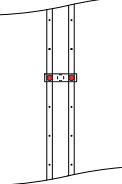



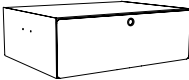
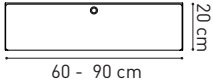
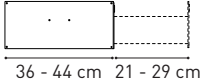
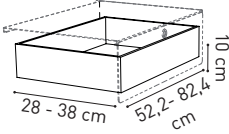
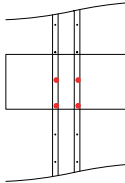

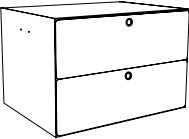
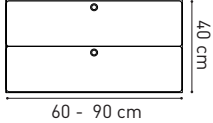
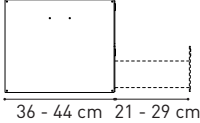
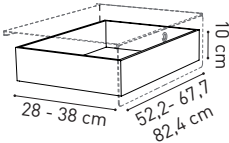
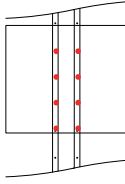

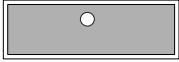
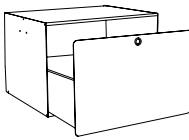
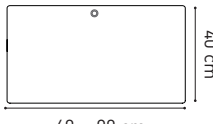
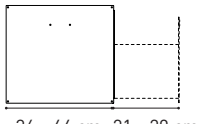
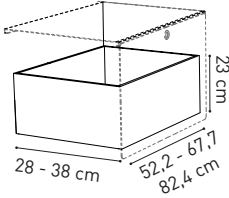
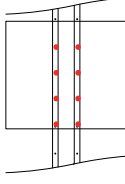

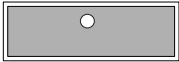
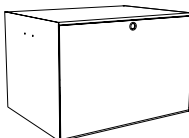
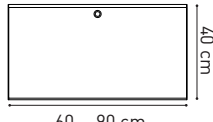
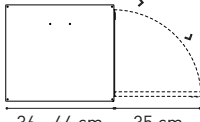
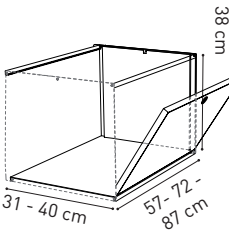
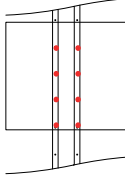

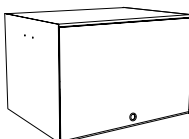
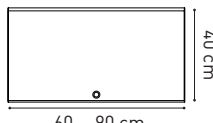
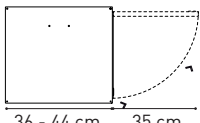
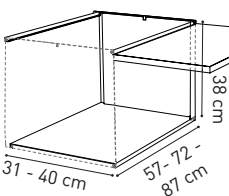
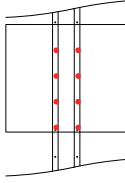





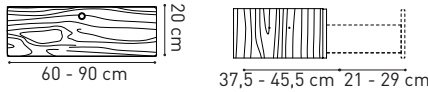
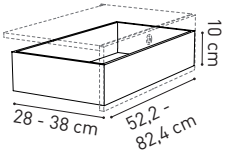
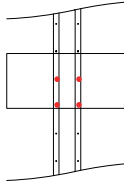



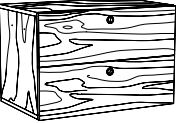
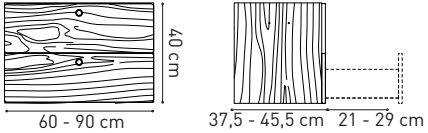
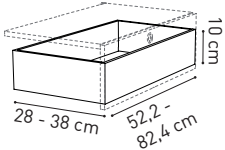
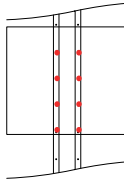

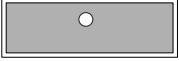
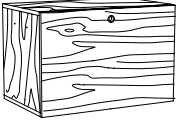
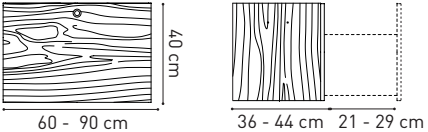
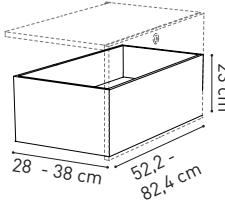
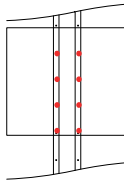

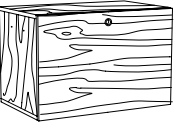
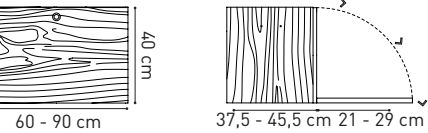
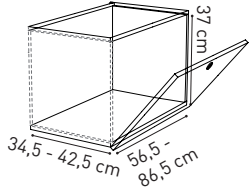
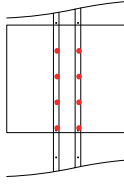

2 fixing points at the ceiling, no fixing point at the floor.

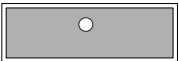
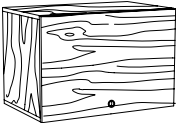
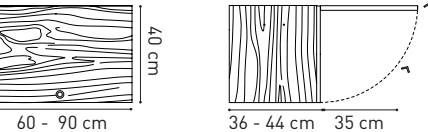
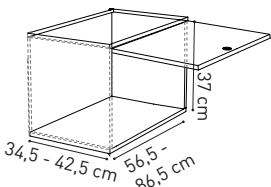
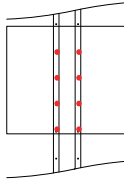
WALL UPRIGHT

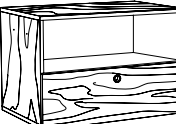
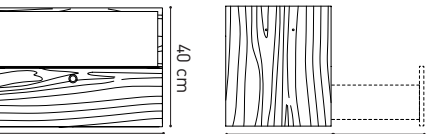
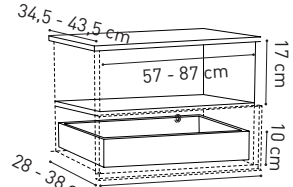
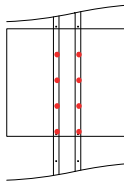

COMPONENT	MEASUREMENTS	ASSEMBLY	CAPACITY	CUSTOM-MADE	NOTES AND TIPS						
REGULAR ALUMINIUM SHELF 		 <p>Takes up 1 pair of holes on the upright.</p>	 <table border="1"> <tr> <td>60 cm</td> <td>90 cm</td> <td>120 cm</td> </tr> <tr> <td>25 kg</td> <td>15 kg</td> <td>25 kg</td> </tr> </table> <p>The 120 cm shelf has a lower reinforcement to improve its weight capacity.</p> 	60 cm	90 cm	120 cm	25 kg	15 kg	25 kg	✂ Dimensions max: 90x36 cm To order, contact the technical office.	Crea una superficie continua affiancando più ripiani.
60 cm	90 cm	120 cm									
25 kg	15 kg	25 kg									
ALUMINIUM SHELF WITH RAISED BORDER 		 <p>Takes up 1 pair of holes on the upright.</p>	 <table border="1"> <tr> <td>60 cm</td> <td>90 cm</td> </tr> <tr> <td>25 kg</td> <td>15 kg</td> </tr> </table>	60 cm	90 cm	25 kg	15 kg	✂ Dimensions max: 90x36 cm To order, contact the technical office.	Create a continuous surface by putting more shelves side by side.		
60 cm	90 cm										
25 kg	15 kg										
WOOD PANEL 		 <p>Takes up 1 pair of holes on the upright.</p>	 <table border="1"> <tr> <td>60 cm</td> <td>90 cm</td> <td>120 cm</td> </tr> <tr> <td>15 kg</td> <td>15 kg</td> <td>15 kg</td> </tr> </table> <p>75 and 90 cm shelves are reinforced with an inner double aluminium sheet to increase their stability.</p>	60 cm	90 cm	120 cm	15 kg	15 kg	15 kg	✂ Dimensions max: 90x36 cm To order, contact the technical office.	
60 cm	90 cm	120 cm									
15 kg	15 kg	15 kg									
PAIR OF WOOD SHELVES SUPPORTS 					Always order a pair of supports for each panel and specify the finish.						
ALUMINIUM HANGER BAR 		 <p>Takes up 1 pair of holes on the upright</p>	 <table border="1"> <tr> <td>60 cm</td> <td>90 cm</td> </tr> <tr> <td>25 kg</td> <td>15 kg</td> </tr> </table>	60 cm	90 cm	25 kg	15 kg	✂ Dimensions max: 90x36 cm To order, contact the technical office.			
60 cm	90 cm										
25 kg	15 kg										

COMPONENT	MEASUREMENTS	INNER DIMENSIONS	ASSEMBLY	CAPACITY	NOTES AND TIPS											
SINGLE DRAWER 	 60 - 90 cm 20 cm	 36 - 44 cm 21 - 29 cm	 28 - 38 cm 52.2 - 82.4 cm 10 cm	Birch plywood inner drawer.  Takes 2 pairs of holes on the upright.	 <table border="1"> <tr> <td>top</td> <td>top</td> </tr> <tr> <td>60 cm</td> <td>90 cm</td> </tr> <tr> <td>20 kg</td> <td>12 kg</td> </tr> <tr> <td colspan="2">inner drawer</td> </tr> <tr> <td colspan="2">25 kg</td> </tr> </table>	top	top	60 cm	90 cm	20 kg	12 kg	inner drawer		25 kg		A cable hole placed on the back of the cabinet is available on request. 
top	top															
60 cm	90 cm															
20 kg	12 kg															
inner drawer																
25 kg																
DOUBLE DRAWER 	 60 - 90 cm 40 cm	 36 - 44 cm 21 - 29 cm	 28 - 38 cm 52.2 - 67.7 cm 10 cm 82.4 cm	Birch plywood inner drawer.  Takes 4 pairs of holes on the upright.	 <table border="1"> <tr> <td>top</td> <td>top</td> </tr> <tr> <td>60 cm</td> <td>90 cm</td> </tr> <tr> <td>20 kg</td> <td>12 kg</td> </tr> <tr> <td colspan="2">inner drawer</td> </tr> <tr> <td colspan="2">25 kg</td> </tr> </table>	top	top	60 cm	90 cm	20 kg	12 kg	inner drawer		25 kg		A cable hole placed on the back of the cabinet is available on request. 
top	top															
60 cm	90 cm															
20 kg	12 kg															
inner drawer																
25 kg																
BIG DRAWER 	 60 - 90 cm 40 cm	 36 - 44 cm 21 - 29 cm	 28 - 38 cm 52.2 - 67.7 cm 23 cm 82.4 cm	Birch plywood inner drawer.  Takes 4 pairs of holes on the upright.	 <table border="1"> <tr> <td>top</td> <td>top</td> </tr> <tr> <td>60 cm</td> <td>90 cm</td> </tr> <tr> <td>20 kg</td> <td>12 kg</td> </tr> <tr> <td colspan="2">inner drawer</td> </tr> <tr> <td colspan="2">25 kg</td> </tr> </table>	top	top	60 cm	90 cm	20 kg	12 kg	inner drawer		25 kg		A cable hole placed on the back of the cabinet is available on request. 
top	top															
60 cm	90 cm															
20 kg	12 kg															
inner drawer																
25 kg																
UNIT WITH TOP DOWN DOOR 	 60 - 90 cm 40 cm	 36 - 44 cm 35 cm	 31 - 40 cm 57 - 72 cm 38 cm 87 cm	 Takes 4 pairs of holes on the upright.	 <table border="1"> <tr> <td>60 cm</td> <td>90 cm</td> </tr> <tr> <td>20 kg</td> <td>12 kg</td> </tr> </table>	60 cm	90 cm	20 kg	12 kg	A cable hole placed on the back of the cabinet is available on request. 						
60 cm	90 cm															
20 kg	12 kg															
UNIT WITH BOTTOM UP DOOR 	 60 - 90 cm 40 cm	 36 - 44 cm 35 cm	 31 - 40 cm 57 - 72 cm 38 cm 87 cm	 Takes 4 pairs of holes on the upright.	 <table border="1"> <tr> <td>60 cm</td> <td>90 cm</td> </tr> <tr> <td>20 kg</td> <td>12 kg</td> </tr> </table>	60 cm	90 cm	20 kg	12 kg	A cable hole placed on the back of the cabinet is available on request. 						
60 cm	90 cm															
20 kg	12 kg															

COMPONENT	MEASUREMENTS	INNER DIMENSIONS	ASSEMBLY	CAPACITY	NOTES AND TIPS										
SINGLE DRAWER 	Birch plywood inner drawer. 		 <p>Takes up 2 pairs of holes on the upright.</p>	 <table border="1"> <tr> <td>top</td> <td>top</td> </tr> <tr> <td>60 cm</td> <td>90 cm</td> </tr> <tr> <td>13 kg</td> <td>11 kg</td> </tr> <tr> <td colspan="2">inner drawer</td> </tr> <tr> <td colspan="2">25 kg</td> </tr> </table>	top	top	60 cm	90 cm	13 kg	11 kg	inner drawer		25 kg		<p>A horizontal or a vertical divider can be added.</p>  <p>A cable hole placed on the back of the cabinet is available on request.</p> 
top	top														
60 cm	90 cm														
13 kg	11 kg														
inner drawer															
25 kg															
DOUBLE DRAWER 	Birch plywood inner drawer. 		 <p>Takes up 4 pairs of holes on the upright.</p>	 <table border="1"> <tr> <td>top</td> <td>top</td> </tr> <tr> <td>60 cm</td> <td>90 cm</td> </tr> <tr> <td>13 kg</td> <td>11 kg</td> </tr> <tr> <td colspan="2">inner drawer</td> </tr> <tr> <td colspan="2">25 kg</td> </tr> </table>	top	top	60 cm	90 cm	13 kg	11 kg	inner drawer		25 kg		<p>A horizontal or a vertical divider can be added.</p>  <p>A cable hole placed on the back of the cabinet is available on request.</p> 
top	top														
60 cm	90 cm														
13 kg	11 kg														
inner drawer															
25 kg															
BIG DRAWER 	Birch plywood inner drawer. 		 <p>Takes up 4 pairs of holes on the upright.</p>	 <table border="1"> <tr> <td>top</td> <td>top</td> </tr> <tr> <td>60 cm</td> <td>90 cm</td> </tr> <tr> <td>13 kg</td> <td>11 kg</td> </tr> <tr> <td colspan="2">inner drawer</td> </tr> <tr> <td colspan="2">25 kg</td> </tr> </table>	top	top	60 cm	90 cm	13 kg	11 kg	inner drawer		25 kg		<p>A horizontal or a vertical divider can be added.</p>  <p>A cable hole placed on the back of the cabinet is available on request.</p> 
top	top														
60 cm	90 cm														
13 kg	11 kg														
inner drawer															
25 kg															
UNIT WITH TOP DOWN DOOR 			 <p>Takes up 4 pairs of holes on the upright.</p>	 <table border="1"> <tr> <td>60 cm</td> <td>90 cm</td> </tr> <tr> <td>13 kg</td> <td>11 kg</td> </tr> </table>	60 cm	90 cm	13 kg	11 kg	<p>A horizontal or a vertical divider can be added.</p>  <p>A cable hole placed on the back of the cabinet is available on request.</p> 						
60 cm	90 cm														
13 kg	11 kg														
UNIT WITH BOTTOM UP DOOR 			 <p>Takes up 4 pairs of holes on the upright.</p>	 <table border="1"> <tr> <td>60 cm</td> <td>90 cm</td> </tr> <tr> <td>13 kg</td> <td>11 kg</td> </tr> </table>	60 cm	90 cm	13 kg	11 kg	<p>A horizontal or a vertical divider can be added.</p>  <p>A cable hole placed on the back of the cabinet is available on request.</p> 						
60 cm	90 cm														
13 kg	11 kg														
STORAGE UNIT WITH DRAWER 	Birch plywood inner drawer. 		 <p>Takes up 4 pairs of holes on the upright.</p>	 <table border="1"> <tr> <td>60 cm</td> <td>90 cm</td> </tr> <tr> <td>13 kg</td> <td>11 kg</td> </tr> </table>	60 cm	90 cm	13 kg	11 kg	<p>A horizontal or a vertical divider can be added.</p>  <p>A cable hole placed on the back of the cabinet is available on request.</p> 						
60 cm	90 cm														
13 kg	11 kg														

✂ Cabinets cannot be custom-made.

STANDARD FINISHES

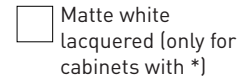
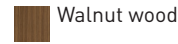
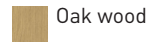

✂ Other wood finishes are not available.

COMPONENTS	MEASUREMENTS	INNER DIMENSIONS	ASSEMBLY	CAPACITY	NOTES AND TIPS
STORAGE UNIT h. 20 cm*	20 cm 60 - 90 cm	36 - 44 cm 17 cm 34,5 - 42,5 cm 57 - 87 cm	Takes up 2 pairs of holes on the upright.	60 cm 90 cm 120 cm 13 kg 11 kg 9 kg	A cable hole placed on the back of the cabinet is available on request.
DOUBLE STORAGE UNIT h. 20 cm	120 cm 36 cm				
STORAGE UNIT h. 40 cm*	40 cm 60 - 90 cm	36 - 44 cm 37 cm 34,5 - 42,5 cm 57 - 87 cm	Takes up 4 pairs of holes on the upright.	60 cm 75 cm 90 cm 13 kg 11 kg 9 kg A horizontal or a vertical divider can be added.	A cable hole placed on the back of the cabinet is available on request.
DOUBLE STORAGE UNIT h. 40 cm	120 cm 40 cm 36 cm				
STORAGE UNIT WITH SINGLE DOOR	40 cm 60 cm 37,5 - 45,5 cm	1,5 cm 34,5 - 42,5 cm 57 cm 37 cm	Takes up 4 pairs of holes on the upright.	top 60 cm 20 kg A horizontal or a vertical divider can be added.	A cable hole placed on the back of the cabinet is available on request.
STORAGE UNIT WITH DOUBLE DOOR	40 cm 90 cm 37,5 - 45,5 cm	1,5 cm 34,5 - 42,5 cm 72,5 - 87 cm 37 cm	Takes up 4 pairs of holes on the upright.	90 cm 12 kg A horizontal or a vertical divider can be added.	A cable hole placed on the back of the cabinet is available on request.
HORIZONTAL DIVIDER*	1,5 cm 34,3 - 42,3 cm 56,9 - 72,4 - 86,9 cm			60 cm 90 cm 20 kg 16 kg Can be added afterwards and be placed at 5 different heights.	
VERTICAL DIVIDER	1,5 cm 34,2 - 42,2 cm 37 cm		Cannot be added afterwards.		
ACCESSORIES FOR 120 CM CABINETS			Accessories are added inside one of the two unit of the 120 cm cabinets.		
DRAWER	20 cm 36 cm 60 cm				
BIG DRAWER	40 cm 36 cm 60 cm				
DOOR	40 cm 40 cm 60 cm				
TOP DOWN/BOTTOM UP DOOR	40 cm 36 cm 60 cm				

Since the K2 is a modular system, each composition is unique and designed according to your needs.

BOOKSHELVES WITH CABINETS | LARGE UNIT

h. 270 cm | l. 383 cm

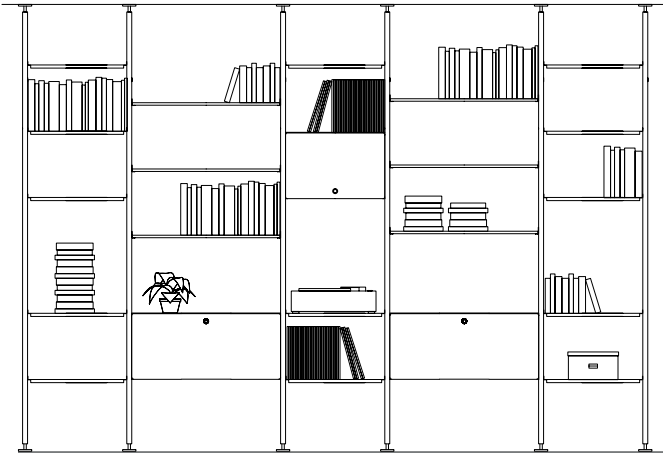

BOOKSHELVES | MEDIUM UNIT

h. 240 cm | l. 257 cm

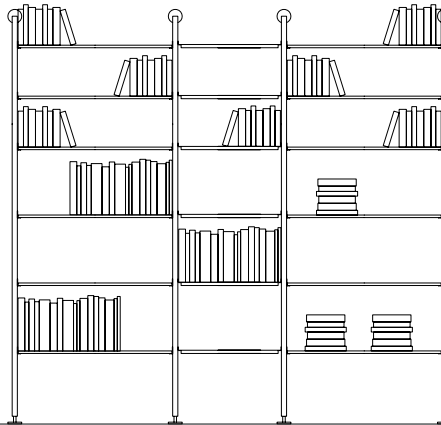

BOOKSHELVES | IRREGULAR UNIT

h. 309 cm | l. 323 cm

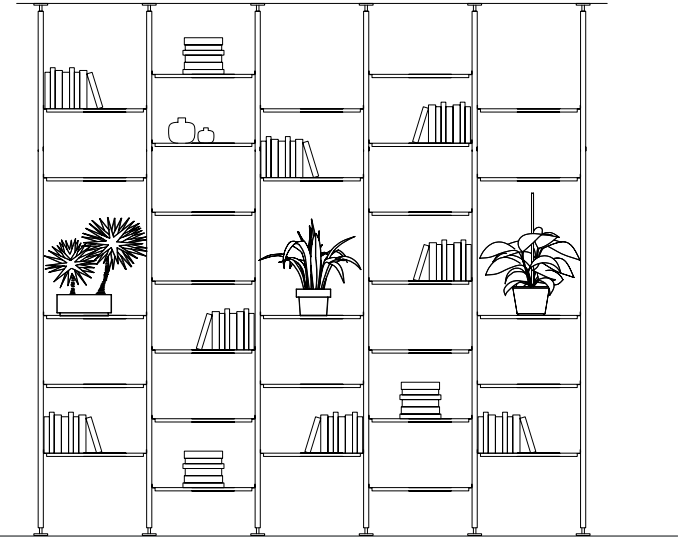

HI-FI AREA

h. 280 cm | l. 317 cm

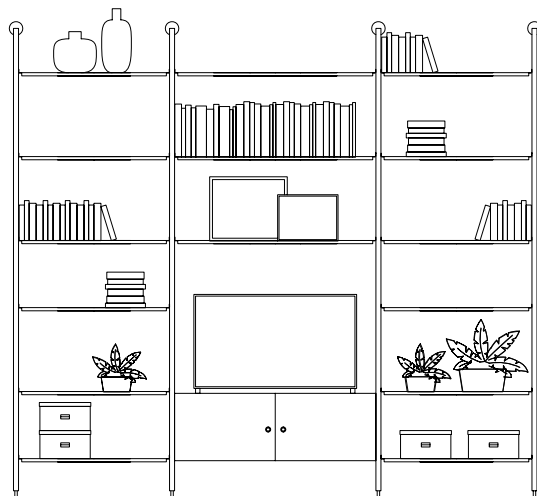

WARDROBE

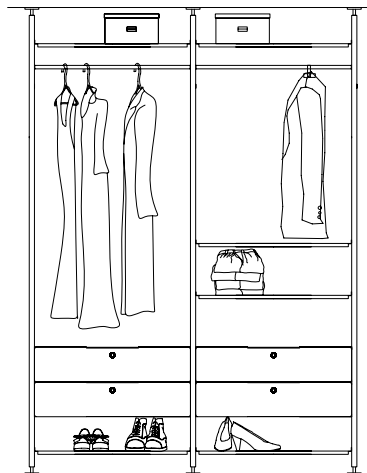

h. 270 cm | l. 154 cm

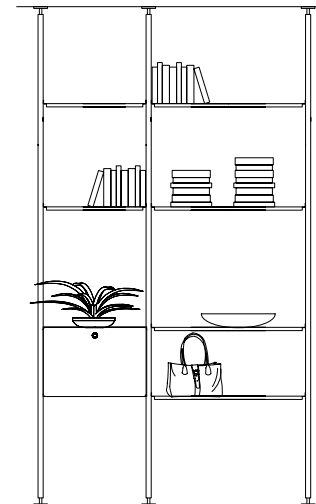

DOORWAY AREA | DIVIDER STRUCTURE

h. 290 cm | l. 164 cm



HARDWARE	SCREWING TYPE	LENGTH/ HEIGHT	DIAMETER
 Wall plugs	-	40 mm	6 mm
 Wall screws	Philips / round head	50 mm	thread: 5 mm / head: 7 mm
 Screws for shelves and cabinets fixing	Philips / flat head	14 mm	thread: 4 mm / head: 7 mm

K2 CLEANING AND CARE TIPS

METAL COMPONENTS



For regular cleaning, use a dish detergent and a wet cloth.



Do not use products that contains acetone, vinegar or ammonia.

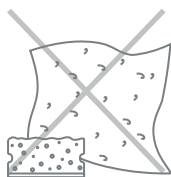

Do not use abrasive sponges or cleaning creams that can scratch the surfaces.

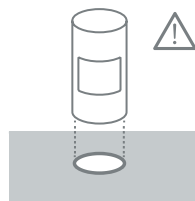

Chemical products such as room fragrances can create stains that can permanently damage the surfaces.

ELEMENTI IN LEGNO



For a regular cleaning use a smooth cloth (wet or dry).



Do not use products that contains acetone, vinegar or ammonia.

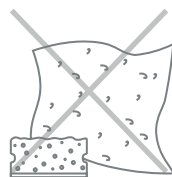

Do not use buffers or microfiber clothes that can scratch the surfaces.

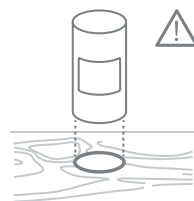

Fat stains of vegetal or animal origin and acid liquids such as sodas can permanently damage the surfaces.

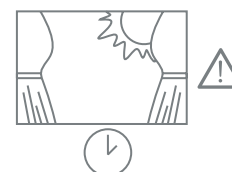

Wood is a living material that has natural color and grain variations. Lights and sun rays create color variations over the time.



Surfaces are sealed with a high quality coat. We recommend to not expose the wood components to a too dry or too wet air. Otherwise, and in spite of the coating, the wood pieces could deform.